

# CANNON

---

## FITZROY PROFILE INBUILT GAS LOG

**FIRE** SPACE  
HEATER

**FITZPIB-02-NG AND FITZPIB-02-LP**  
TO SUIT MOCK FIREPLACE INSTALLATIONS

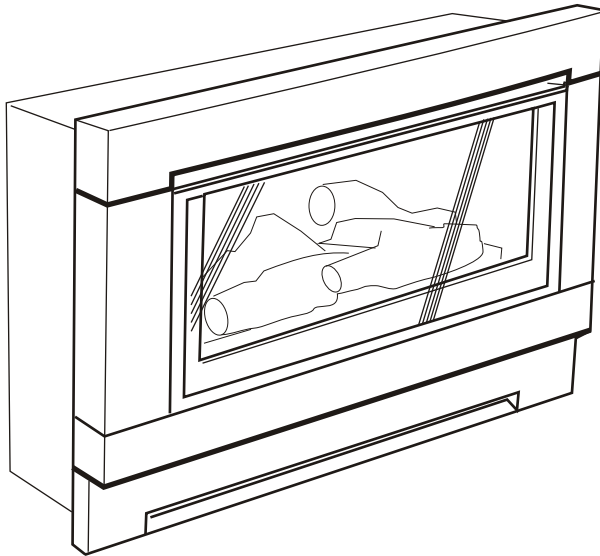

### INSTALLATION INSTRUCTIONS FOR FITMENT INTO A COMBUSTIBLE ENCLOSURE

This heater is for use with Natural and Propane gases.

Read these instructions in conjunction with heater  
installation instructions

# CONTENTS

ITEM	PAGE.
GENERAL	Page 1
MOCK FIREPLACE ENCLOSURE RECOMMENDATIONS	Page 2
MOCK CAVITY DIMENSIONS	Page 3
OVERALL DIMENSIONS OF INSERT CABINET	Page 4
FITMENT OF SPACER BRACKETS AND BLANKET	Page 5
INSTALLATION INTO WALL CAVITY - METHOD A	Page 6 & 7
INSTALLATION INTO COMBUSTIBLE CAVITY - METHOD B	Page 8
MAINTENANCE	Page 9

## **GENERAL**

THIS HEATER SHALL ONLY BE INSTALLED BY AN AUTHORIZED PERSON. THIS APPLIANCE SHALL BE INSTALLED IN ACCORDANCE WITH THE MANUFACTURERS INSTALLATION INSTRUCTIONS. AS 5601, MUNICIPAL BUILDINGS CODES, ELECTRICAL WIRING REGULATIONS AND ANY OTHER STATUTORY REGULATIONS.

TO CONFORM WITH THE AGA APPROVAL REQUIREMENTS THE SPACERS MUST BE PERMANENTLY FITTED TO MAINTAIN THE REQUIRED CLEARANCE FROM COMBUSTIBLE MATERIALS.

THESE INSTRUCTIONS TO BE READ IN CONJUNCTION WITH THE HEATER INSTALLATION BOOKLET.

THIS HEATER MUST BE INSTALLED CORRECTLY TO PROVIDE SAFE AND RELIABLE OPERATION.

PLEASE TAKE THE TIME TO READ THESE INSTRUCTIONS AND TO FAMILIARIZE YOURSELF WITH THE CORRECT INSTALLATION METHODS.

CORRECT FLUE DESIGN AND ALLOWANCE FOR VENTILATION MUST BE CONSIDERED.

AVOID THE USE OF FLUE BENDS IF POSSIBLE.

ALWAYS ALLOW FOR THE COMPLETE REMOVAL OF THE HEATER WITHOUT ANY DIFFICULTIES AND MAKE SURE THAT THE FLUE IS RIGID AND SELF SUPPORTING. THE BOTTOM LENGTH OF THE FLUE MUST FIT INSIDE OF THE ADAPTING SPIGOT PIECE. THE FLUE ADAPTING PIECE MUST BE A SLIP FIT OVER THE RECTANGULAR SPIGOT ON THE HEATER.

MAKE SURE THAT THE HEATER IS FULLY COMMISSIONED AND BE CERTAIN TO CONDUCT A TEST OF THE INTEGRITY OF THE FLUE OPERATION, TAKING INTO ACCOUNT ANY INFLUENCES CREATED BY RANGE HOODS, EXHAUST FANS, CENTRAL HEATING ETC.

TO AVOID ANY UNNECESSARY DELAYS AND INCONVENIENCE TO YOUR CUSTOMER, LEASE CONTACT OUR TECHNICAL SUPPORT SECTION IF THE INSTALLATION IS UNUSUAL AND REQUIRES FURTHER ADVICE OR ASSISTANCE.

## MOCK FIREPLACE ENCLOSURE RECOMMENDATIONS

THE ENCLOSURE CAN BE FABRICATED USING ANY MATERIALS PROVIDING THAT SPACER BRACKETS ARE FITTED TO THE HEATER PROVIDING ADEQUATE CLEARANCES TO COMBUSTIBLE MATERIALS. (SEE FIG 5)

THE AREA OF THE CAVITY MUST NOT EXCEED OUR DIMENSIONS AS SHOWN IN THE DIAGRAM. (SEE BELOW)

IF THE ENCLOSURE IS LARGER THAT OUR DIMENSIONS ALLOW, A SEPARATE BOXED SECTION AROUND THE HEATER WILL NEED TO BE CONSTRUCTED.

THE HEATER MUST SIT ON A SOLID, SEALED BASE AND THE ENCLOSURE MUST BE SEALED FROM ANY DRAUGHT AND BE INSULATED AS NECESSARY TO ELIMINATE LOW TEMPERATURES.

OUR BROCHURE ILLUSTRATES AN ENCLOSURE CONSTRUCTED TO AN EXISTING ROOM WITH A SOLID FLOOR AND CEILING, ANY OTHER ENCLOSURE MUST HAVE THE SAME CHARACTERISTICS OF BEING SEALED FROM ANY DROUGHT AND SUITABLY INSULATED FROM LOW TEMPERATURES. FAILURE TO ADHERE TO THIS REQUIREMENT WILL RESULT IN UNRELIABLE OPERATION OR FAILURE TO OPERATE CORRECTLY AND IS NOT COVERED BY OUR WARRANTY CONDITIONS

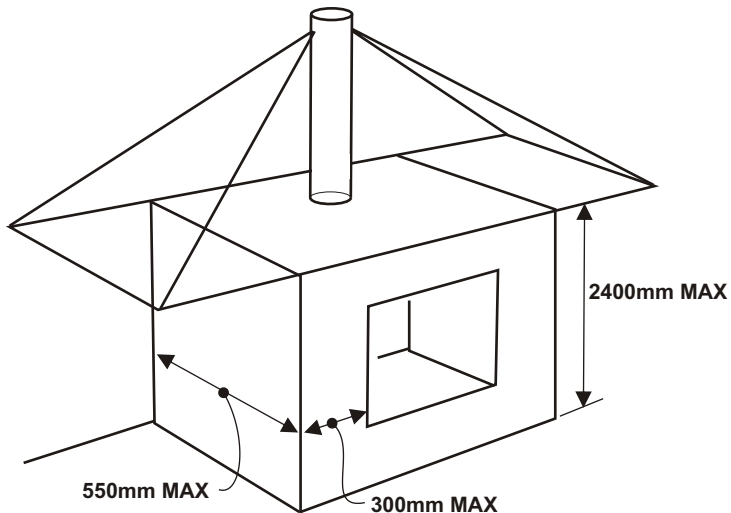

**FIG 1.**

## MOCK CAVITY DIMENSIONS - FITZROY PROFILE

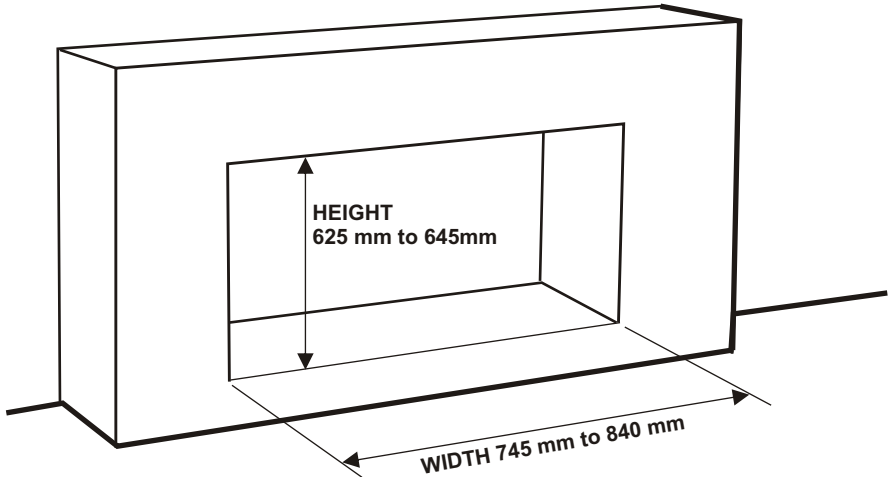

**FIG 2.**

**DEPTH OF CAVITY = HEATER + ADAPTOR + FLUE CLEARANCE**

**MIN 495 mm = 345mm + 125mm + 25mm**

**MAX 550 mm = 345mm + 125mm + 80mm**

### **CLEARANCE FROM COMBUSTIBLES.**

BETWEEN HEATER CABINET AND OTHER  
COMBUSTIBLE SURFACES.

\* 20 mm CLEARANCE FROM BOTH TOP  
AND SIDE SURFACES.

\* 50 mm CLEARANCE FROM REAR.

\* 100 mm CLEARANCE BETWEEN SIDE OF  
THE HEATER FRONT AND  
COMBUSTIBLES.

ADDITIONAL CLEARANCES ARE SPECIFIED  
IN THE HEATER INSTALLATION  
INSTRUCTION BOOKLET. ( **FIG 10.**)

**OVERALL DIMENSIONS OF THE INSERT CABINET.  
(SEE FIG 3 AND 4. )**

* HEIGHT	620 mm
* WIDTH	735 mm
* DEPTH	395 mm
* DEPTH (WITH TRANSITION ADAPTOR FITTED)	470 mm

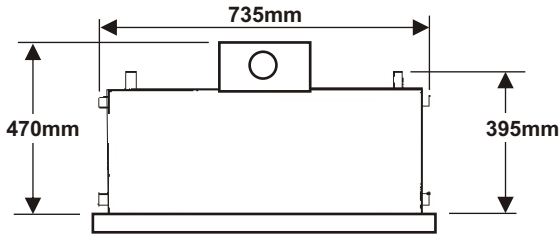

**FIG 3.**

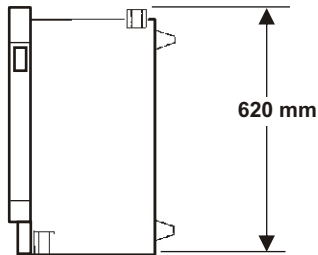

**FIG 4.**

**THE HEATER FOR INSTALLATION INTO A MOCK  
FIREPLACE IS SUPPLIED WITH THE FOLLOWING PARTS.  
( SEE FIG 5.)**

F1417	FLUE TRANSITION ADAPTOR	1 OFF
F1404	REAR BRACKETS	2 OFF
F1405	TOP & SIDE SPACER BRACKETS	4 OFF
F1406	INSULATION BLANKET	1 OFF
F2663	INSTRUCTION BOOKLET	1 OFF
F2517	FLUE OUTLET	1 OFF

## FITMENT OF SPACER BRACKETS AND BLANKET.

1. FIT TOP AND SIDE BRACKETS TO HEATER CABINET ON DIAGONAL CORNERS AS SHOWN EACH SIDE. ( SEE FIG 5.) USING EXISTING SCREW POSITIONS.
2. FIT REAR SPACER BRACKETS TO HEATER CABINET ON DIAGONAL CORNERS AS SHOWN. ( SEE FIG 5.)
3. POSITION INSULATION BLANKET ON HEATER TOP ALIGNED WITH EDGES. SECURE WITH MASKING TAPE AS SHOWN. ( SEE FIG 5.)
4. REMOVE THE FLUE OUTLET SUPPLIED WITH HEATER AND REPLACE WITH FLUE OUTLET SUPPLIED WITH MOCK KIT.

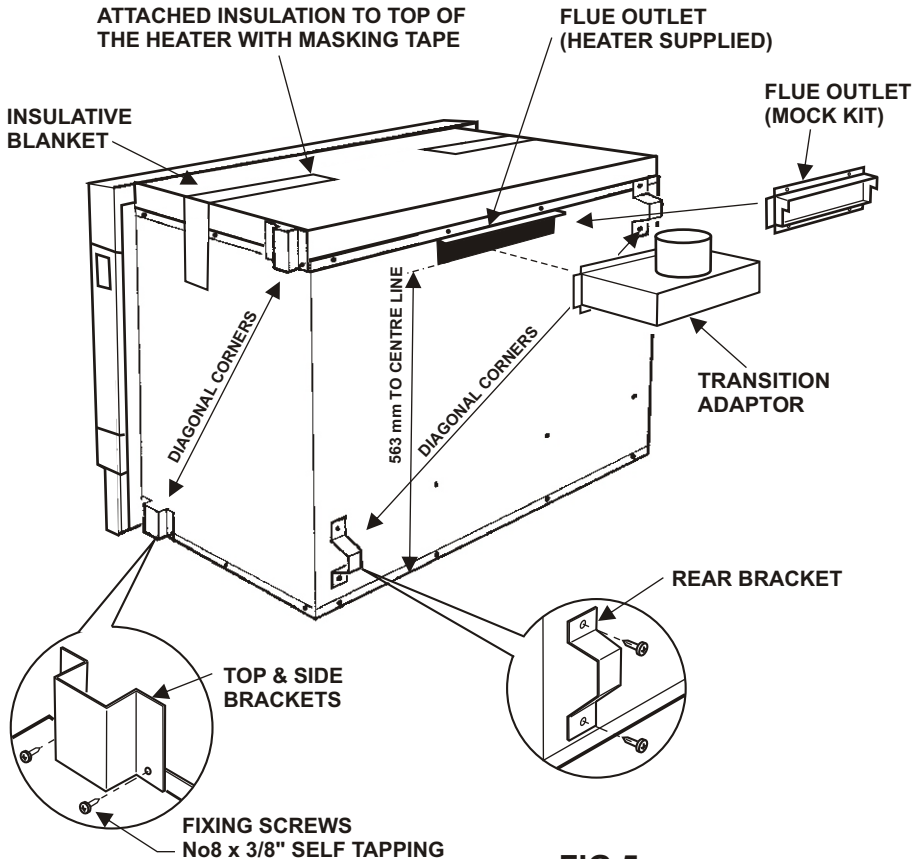

FIG 5.

# **INSTALLATION INTO WALL CAVITY. ( TWIN SKIN FLUE )**

## **METHOD A**

THE MINIMUM WALL CAVITY REQUIRED IS 35 mm. SELECT A PAIR OF STUDS IN FRONT OF WHICH THE HEATER IS TO BE INSTALLED. THE GAP BETWEEN THE STUDS SHOULD BE NO LESS THAN 35 mm AND NO GREATER THAN 610 mm. ENSURE CEILING AND ROOF MEMBERS WILL NOT OBSTRUCT VERTICAL PATH OF FLUE.

### **METHOD.**

1. CUT FLUE OPENING CENTRAL TO WALL STUDS IN THE WALL CLADDING. ( SEE FIG 7. )
2. CUT AWAY TOP WALL PLATE AND ANY EXISTING NOGGINS BETWEEN STUDS.
3. CUT CLEARANCE HOLE FOR 100 mm DIAMETER FLUE PIPE IN THE ROOF.
4. FIT HEADER ASSEMBLY INTO FLUE OPENING LEAVING A 12 mm GAP BETWEEN TOP OF THE HEADER ASSEMBLY AND WALL CLADDING AS SHOWN.
5. DRILL 4 HOLES THROUGH HEADER FLANGES AT STUD CENTRES AND USE CLOUTS OR SCREWS TO ATTACH TO WALL.
6. MEASURE DISTANCE FROM FLOOR TO TOP OF FLUE OUTLET OF THE HEATER.
7. ADJUST ELBOW TO THE DISTANCE MEASURED PLUS 2 mm AND TIGHTEN SCREW. ENSURE FLUE ELBOW IS HORIZONTAL.
8. BEND TABS IN AT THE BASE OF THE TWIN SKIN FLUE AND LOWER TWIN SKIN FLUE DOWN THE WALL CAVITY.
9. SLIDE TOP PLATE FLUE SUPPORT OVER TWIN SKIN FLUE, CENTRALISE AND NAIL TO THE TOP PLATE.
10. SLIDE FLUE ADAPTER INSIDE INNER SKIN AT TOP OF TWIN SKIN FLUE.
11. FIT SMALL END OF THE 100 mm DIA FLUE PIPE INTO FLUE ADAPTER. FIT FURTHER LENGTHS WITH SMALL END DOWNWARD AS REQUIRED. (THE SMALL END HAS A SWAGE 35 mm FROM THE END.)
12. FLASH BETWEEN FLUE PIPE AND ROOF CLADDING USING EITHER LEAD FLASHING OR AN APPROVED SILICON RUBBER PIPE FLASHING BOOT.
13. FIT COWL TO THE TOP OF THE FLUE PIPE, ALIGN THE SCREW HOLES AND FASTEN THE 3 SCREWS SUPPLIED.

# METHOD A

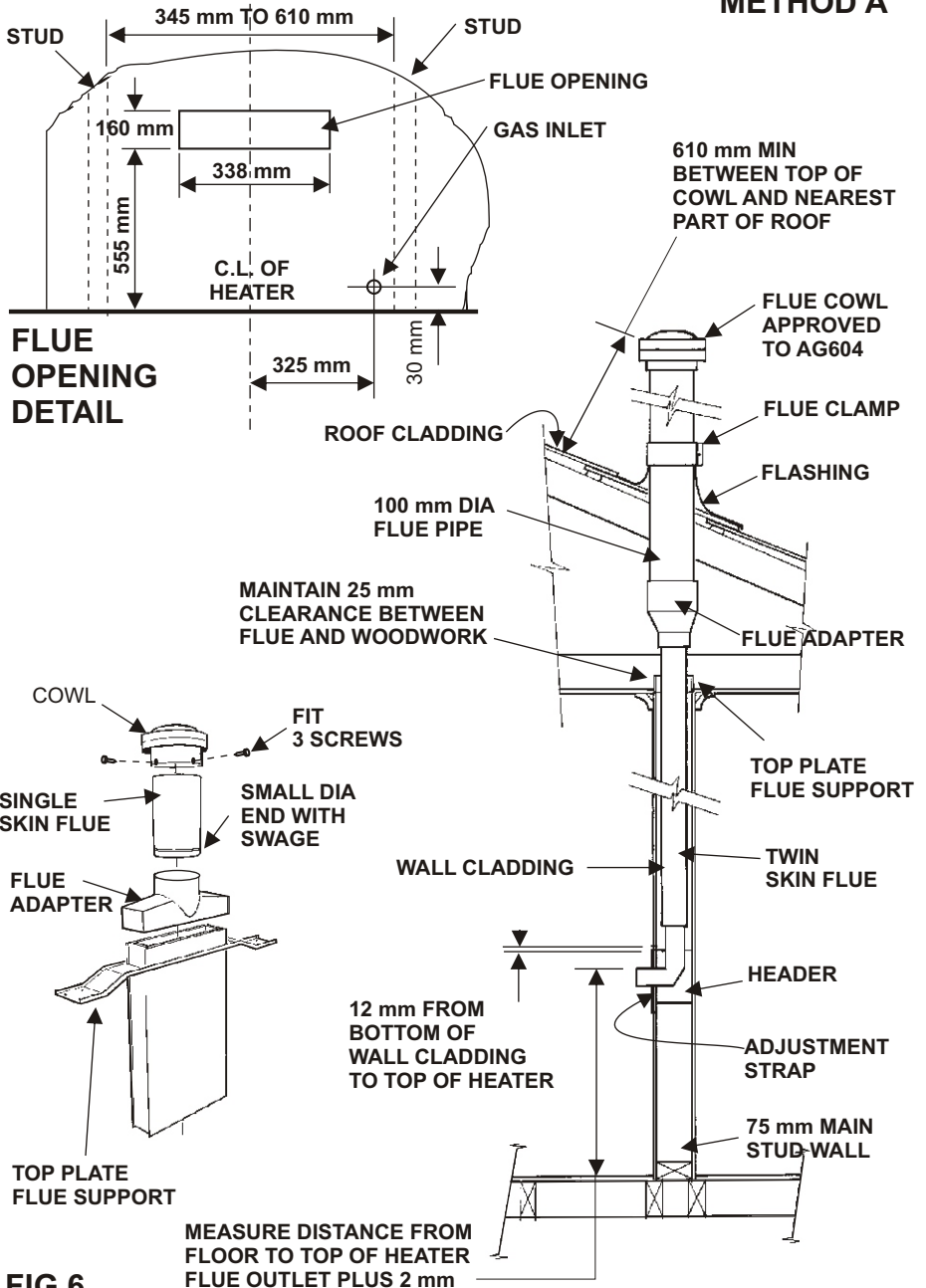

**FIG 6.**

MAKE SURE THERE IS ADEQUATE VENTILATION IN ROOM.

# INSTALLATION INTO A COMBUSTIBLE ENCLOSURE

( SINGLE SKIN FLUE )

METHOD B

610 mm BETWEEN  
TOP OF COWL AND  
NEAREST PART OF ROOF

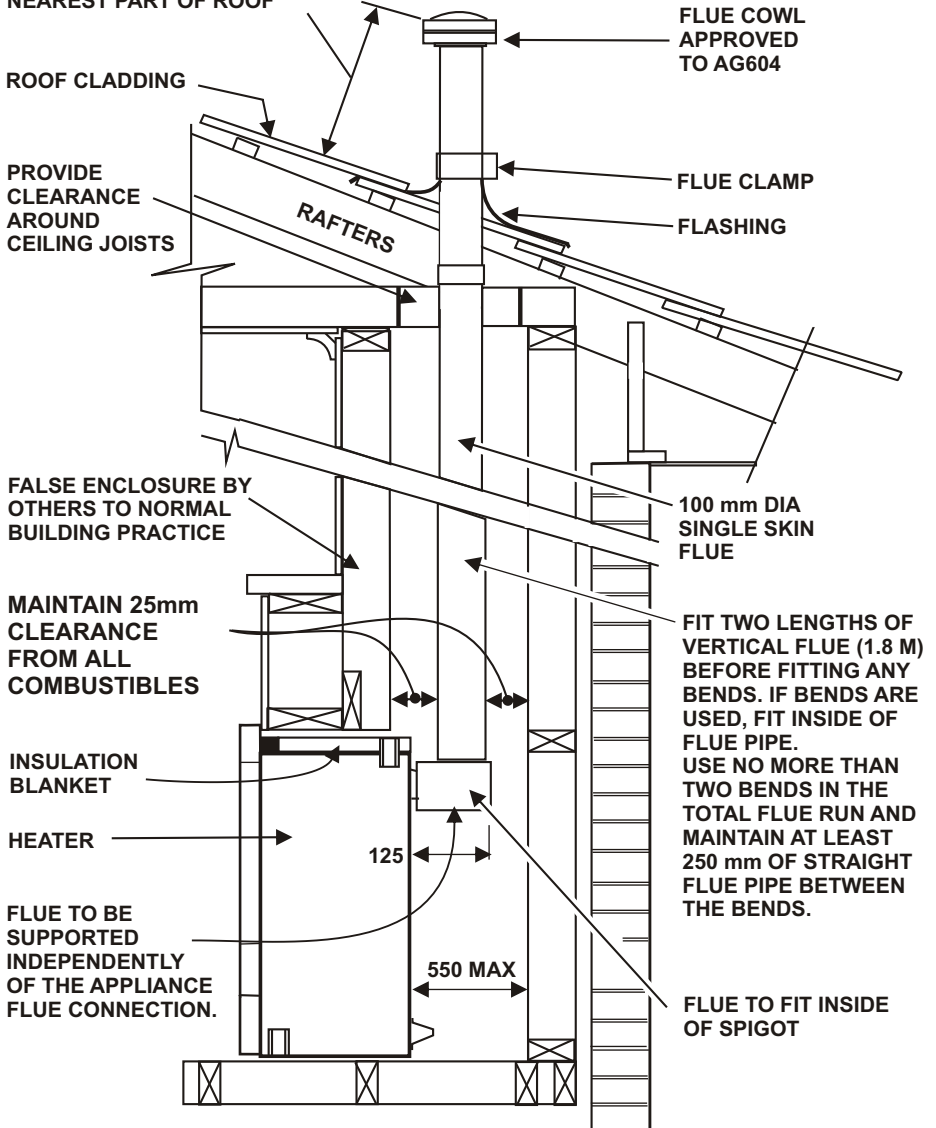

FIG 7.

RECTANGULAR TO ROUND 90 DEG TRANSITION ADAPTOR SUPPLIED WITH MOCK KIT.

## **MAINTENANCE**

IF YOUR HEATER REQUIRES ATTENTION CONTACT:

**SAMPFORD AND STAFF PTY LTD**  
ON

**PH: 1300 727 421**

**or**

**FAX: 1300 727 425**

REVISION "E"

DATED: APRIL 2007

REF: F2771-E